

Earth-Rite® FIBC

Static grounding protection for Type C FIBC located in potentially flammable/combustible gas or dust atmospheres



The **Earth-Rite® FIBC** system validates and monitors the resistance of Type C FIBC bags ensuring that the conductive elements of the bag are capable of dissipating electrostatic charges in compliance with IEC 61340-4-4 “Standard test methods for specific applications - Electrostatic classification of flexible intermediate bulk containers (FIBC)” and NFPA 77 “Recommended Practice on Static Electricity”.

Enquiry > Click here to submit a product related query or a request for quotation.

The Earth-Rite FIBC system can be installed and setup to ensure that operators ground the bag before filling or emptying operations are started. During the bag filling / emptying process the Earth-Rite FIBC system continuously monitors the resistance of the bag so that if it rises above the recommended level of 1×10^7 ohms (10 meg-ohm) this dangerous situation can be indicated to operators and the process halted, either manually or via the system’s pair of NO/NC volt free contacts.

This feature ensures the generation and accumulation of static charges on the bag is stopped eliminating the risk of an incendive electrostatic spark discharge.

To compensate for normal wear and tear on Type C bags it is important to ensure the bag maintains its capacity to dissipate charge and also ensure the ground connection between the bag and plant earth grounding point is functioning correctly.

Newson Gale can also provide FIBC grounding systems that can validate and monitor Type C bags designed with an upper resistance threshold of 1×10^8 ohms (100 meg-ohm).



Earth-Rite FIBC Type C Static Grounding System

The Earth-Rite FIBC includes:

- > SDP Controller (static dissipative GRP) with Intrinsically Safe Monitoring Circuits.
- > FIBC Grounding Clamp with single conductor Hytrell® Protected Cable.
- > Junction Box with Stowage Pin for stowing FIBC Grounding Clamp.

Earth-Rite® FIBC Static grounding protection for Type C FIBC located in potentially flammable/combustible gas or dust atmospheres

Features and Benefits

Attention grabbing LEDs

Three green LEDs continuously pulse informing operators that the FIBC bag to be protected from static discharges is correctly grounded. When the system is not in use, or when it detects the resistance in the static dissipative loop is higher than 1×10^7 ohms, a red LED illuminates the indicator panel located in the static dissipative GRP indicator station.

Continuous Ground Loop Monitoring

Monitors the resistance of the static dissipative loop through the FIBC bag back to the Earth-Rite FIBC via the plant earth grounding point. If the system detects that resistance in the loop is higher than 1×10^7 ohms, it engages a pair of output contacts.

Two volt free output contacts

The primary contact can interlock with electro-mechanical devices or PLC systems to shutdown the flow of product. The secondary contact can interface with attention grabbing audible alarms or strobe lights to provide an extra degree of safety over the hazard.

Easy Installation

Simple to mount GRP enclosures complemented by straightforward cabling and PCB system wiring. Flexible hazardous area enclosure location options with separate IS monitoring / indicator and Power supply PCBs. Power supply PCB can run off both 240 V and 110 V mains / line supply and 24 V / 12 V DC voltage supply.



X45F FIBC stainless steel grounding clamp with Quick Connect and optional lengths of Hytrel protected single core cable included.

- > IEC 60079-32, IEC 61340-4-4 and NFPA 77, state that the resistance through a Type C FIBC bag should not exceed 1×10^7 ohms (10 meg-ohm).
- > CLC/TR: 50404, which was superseded by IEC 60079-32, states that the resistance through a Type C FIBC bag should not exceed 1×10^8 ohms (100 meg-ohm).

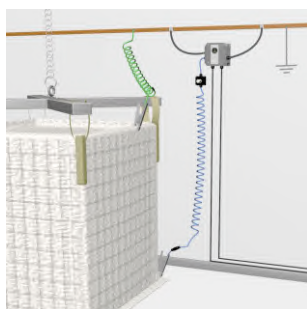

The Earth-Rite FIBC ensures Type C FIBC bags are protected from incendive electrostatic discharges during bag filling and discharging operations.



The Earth-Rite FIBC can be installed in Zoned / Classified combustible dust atmospheres. If gas and vapour atmospheres are present an Ex(d) / XP, Zone 1 / Class I, Div. 1 system may be specified.

The Earth-Rite® FIBC forms part of the Earth-Rite® range of Static Grounding and Bonding Equipment available from Newson Gale.

Options

Ex(d)XP Flameproof enclosure for gas & vapour atmosphere.



A 2nd clamp connects FIBC bag to verified earth grounding point.

Explosion Proof Strobe Light

Intrinsically Safe (I.S) Switching PCB

IEC/Cenelec (European) and NEC/CEC (North American) versions available

Certification

   **SIL 2**

Ingress Protection
IP 66

Temperature Range
-13°F to +131°F - CSA
-40°C to +55°C - ATEX / IECEx

Power Supply
110/120V or 220/240V AC, 50-60 Hz, 12V or 24V DC

Earth-Rite® FIBC Static grounding protection for Type C FIBC located in potentially flammable/combustible gas or dust atmospheres

Technical Specification

(Zone 2 Gas / Vapour Installations - Zone 21 & 22 Dust Atmospheres)

Power Supply & Monitoring-Unit	
Power supply	108/125 V or 216/250 V AC, 50-60 Hz 12 V or 24 V DC
Power rating	10 watt
Ambient temperature range	-40°C to +55°C
Ingress protection	IP 66
Weight	1.5 kg (3.3 lbs) nett
Construction	Carbon-Loaded GRP
Monitoring circuit	Intrinsically safe
Operational series ground resistance	$\leq 1 \times 10^6$ or 1×10^7 Ohm
Output Relay Contact Rating	2 volt free change over switch contacts, 250 V AC, 5 A, 500 VA max resistive, 30 V DC, 2 A, 60 W max resistive.
I.S. Switching PCB (NAMUR compatible)	30 V DC, 500 mA Li = 0H, Ci = 0F Optional extra - See system options
Cable Entries	7 x M20 (2 x plugged)
Junction Box/Stowage Point	
Enclosure Material	GRP with carbon loading
Terminals	2 x 2.5 mm ² conductor capacity
Stowage Device	Insulated 5 mm diameter pin
Cable Entries	1 x 20 mm
Clamp Cable Connection	Quick Connect
Grounding Clamp	
Clamp Design	1 pole with single stainless steel contact
Body	Stainless Steel (SS 304)
Certification	Ex II 1 GD T6
Spiral Cable	
Cable	Blue Cen-Stat Hytrel sheath (Static dissipative, chemical & abrasion resistant)
Conductors	1 x 4.00 mm ² steel
Length	5 metres extended, 1 metre unextended (other lengths available, please enquire)

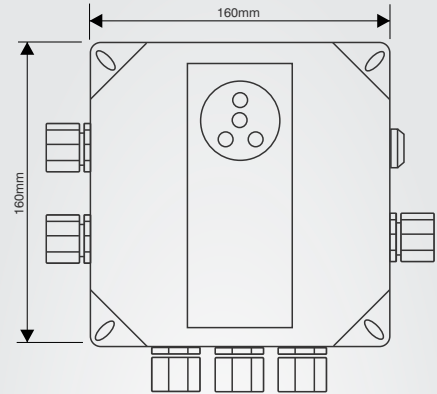

Earth-Rite FIBC consisting of ground status monitoring module and 230V / 110V power supply.

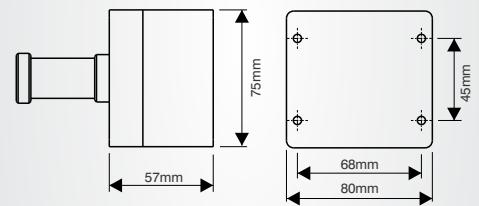

Junction Box/Stowage Point

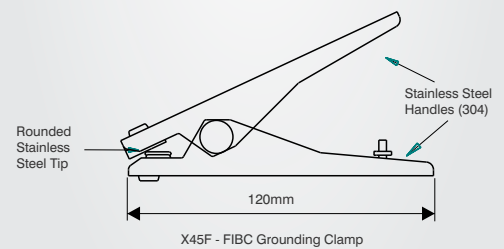

ATEX certified 2 Pole stainless steel grounding clamp.

Earth-Rite® FIBC Static grounding protection for Type C FIBC located in potentially flammable/combustible gas or dust atmospheres

Hazardous Area Certification

Europe / International:

IECEX

Ex nA nC [ia] IIC T4 Gc(Ga) (gas & vapour).
 Ex tb IIIC T70°C Db (combustible dusts).
 Ta = -40°C to +55°C.
 IECEX SIR 09.0097
 IECEX certifying body: SIRA.

ATEX

Ex II 3(1) G
 Ex II 2D
 Ex nA nC [ia] IIC T4 Gc(Ga)
 Ex tb IIIC T70°C Db
 Ta = -40°C to +55°C.
 Sira 09ATEX2247
 ATEX Notified Body: SIRA.

North America:

NEC 500 / CEC (Class & Division)

Associated Equipment [Ex ia] for use in
 Class I, Div. 2, Groups A, B, C, D;
 Class II, Div. 2, Groups E, F, G
 Class III, Div. 2,
 Providing Intrinsically Safe circuits for
 Class I, Div. 1, Groups A, B, C, D;
 Class II, Div. 1, Groups E, F, G;
 Class III, Div. 1;
 When installed per Control Dwg;
 ERIL-Q-10165 cCSAus
 Ta = -25°C to +55°C.
 Ta = -13°F to +131°F.

OSHA recognised NRTL: CSA.

NEC 505 & 506 (Class & Zoning)

Class I, Zone 2, (Zone 0), AEx nA[ia] IIC T4
 (gas & vapour).
 Class II, Zone 21, AEx tD[iaD] 21, T70°C,
 (combustible dusts).

CEC Section 18 (Class & Zoning)

Class I, Zone 2 (Zone 0) Ex nA[ia] IIC T4
 DIP A21, IP66, T70°C

Additional Certification

Safety Integrity Level:

SIL 2 (in accordance with IEC/EN 61508).

SIL assessment body:

Exida

EMC Tested:

to EN 61000-6-3, EN 61000-6-2
 FCC - Part 15 (Class B)



Earth-Rite® FIBC Static grounding protection for Type C FIBC located in potentially flammable/combustible gas or dust atmospheres

Technical Specification

(Zone 1 Gas / Vapour Installations - Zone 21 Dust Atmospheres)

Monitoring-Unit	
Power supply	110/120 V or 220/240 V AC, 50-60 Hz 12 V or 24 V DC
Power rating	10 watt
Ambient temperature range	-40°C to +55°C
Ingress protection	IP 66
Weight	4.5 kgs (9.9 lbs) nett
Construction	Copper-free cast aluminium
Monitoring circuit	Intrinsically safe
Operational series ground resistance	$\leq 1 \times 10^8$ or 1×10^7 Ohm
Output relay contact rating	2 off voltage free change-over switch contacts, 250 V AC, 5 A, 500 VA max resistive 30V DC, 2 A, 60 W max resistive
I.S. Switching PCB (NAMUR compatible)	30 V DC, 500 mA Li = 0H, Ci = 0F Optional extra - See system options
Cable entries	7 x M20 (2 x plugged)
Junction Box/Stowage Point	
Enclosure Material	GRP with carbon loading
Terminals	2 x 2.5 mm ² conductor capacity
Stowage Device	Insulated 20 mm Ø pin
Cable Entries	1 x 20 mm
Clamp Cable Connection	Quick Connect
Grounding Clamp	
Clamp Design	1 pole with single stainless steel contact
Body	Stainless Steel
Certification	Ex II 1 GD T6
Spiral Cable	
Cable	Blue Cen-Stat Hytrel sheath (Static dissipative, chemical & abrasion resistant)
Conductors	1 x 4.00 mm ² steel
Length	5 metres extended, 1 metre unextended (other lengths available - please enquire)

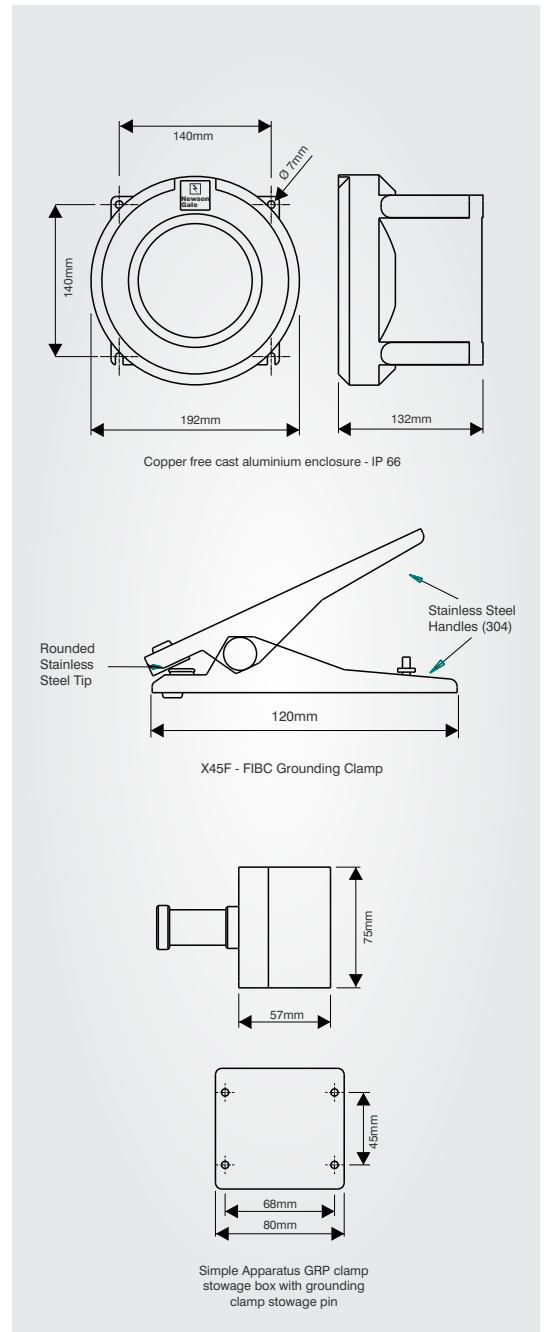

Earth-Rite® FIBC Static grounding protection for Type C FIBC located in potentially flammable/combustible gas or dust atmospheres

Hazardous Area Certification

Europe / International:	North America:
<p>IECEX Ex d[ia] IIC T6 Gb(Ga) (gas & vapour). Ex tb IIIC T80°C IP66 Db (combustible dusts). Ta = -40°C to +55°C. IECEX SIR 09.0018 IECEX certifying body: SIRA.</p> <p>ATEX Ex II 2(1)GD Ex d[ia] IIC T6 Gb(Ga) Ex tb IIIC T80°C IP66 Db Ta = -40°C to +55°C. Sira 09ATEX2047 ATEX Notified Body: SIRA.</p>	<p>NEC 500 / CEC (Class & Division) Associated Equipment [Ex ia] for use in Class I, Div. 1, Groups A, B, C, D; Class II, Div. 1, Groups E, F, G; Class III, Div. 1, Providing intrinsically safe circuits for Class I, Div. 1, Groups A, B, C, D; Class II, Div. 1, Groups E, F, G; Class III, Div. 1, When installed per Control Dwg; ERII-Q-10110 cCSAus Ta = -40°C to +50°C. Ta = -40°F to +122°F.</p> <p>OSHA recognised NRTL: CSA.</p> <p>NEC 505 & 506 (Class & Zoning) Class I, Zone 1 [0] AEx d[ia] IIC T6 Gb(Ga) (gas & vapour). Class II, Zone 21 [20] AEx tD [iaD] 21 T80°C (combustible dusts).</p> <p>CEC Section 18 (Class & Zoning) Class I, Zone 1[0] Ex d[ia] IIC T6 Gb(Ga) DIP A21, IP66, T80°C</p>

Additional Certification

Safety Integrity Level:	SIL 2 (in accordance with IEC/EN 61508).
SIL assessment body:	Exida
EMC Tested:	to EN 61000-6-3, EN 61000-6-2 FCC - Part 15 (Class B)



Earth-Rite® FIBC Static grounding protection for Type C FIBC located in potentially flammable/combustible gas or dust atmospheres

System Options

Newson Gale supplies a range of product options that enhance the control and general safety of transfer processes and aid engineers with system installations and routine system service checks. Contact Newson Gale or your local Newson Gale representative for more information on the range of options available.

Installer's Kit

This kit provides installation engineers with the necessary Ex (d) enclosure glands (x5) and system cable (x3) required to complete an **Earth-Rite RTR** or **Earth-Rite PLUS** installation as specified in the system installation manuals. Two of the glands cater armoured cable diameters ranging from 9 mm to 13.5 mm. Three glands cater for IS current carrying non-armoured cable with cable diameters ranging from 4 mm to 8.4 mm. * For areas not requiring IIC apparatus.

- > Ex (d) IP68 glands (x2) for armoured cable 9 mm to 13.5 mm Ø*
- > Ex (d) IP68 glands (x3) for non-armoured cable 4 mm to 8.4 mm Ø*
- > 3 m of 2 core conductor cable (x1) to connect system enclosure to clamp storage box
- > 1 m of solid green earth loop cable (x2), with Ex (d) glands, PCB connectors and 10 mm bolt eyelets attached

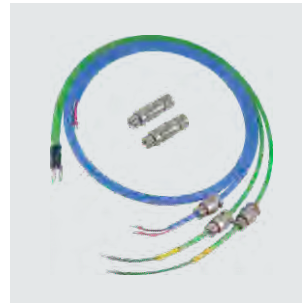

Installer's Kit

Product Code: ER2KITA
(Power cable and interlock cable not supplied).

Intrinsically Safe (I.S) Switching PCB

The I.S Switching PCB is an additional circuit board added to Newson Gale system enclosures that enable users to directly interface with, and switch intrinsically safe circuits without the need for additional equipment. The I.S Switching PCB is designed not to affect the I.S signals electrical parameters and is compatible with the **Earth-Rite RTR**, **MGV**, **PLUS** and **FIBC** platforms.

- > 30 V DC, 500 mA
- > Li = 0H, Ci = 0F
- > Suitable for Ex ia, ib, ic rated intrinsically safe circuits only
- > NAMUR Compatible

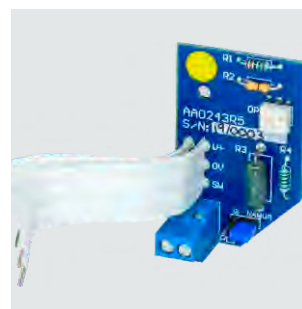

I.S Switching PCB

Product Code: ER2/IS/KIT

Earth-Rite® FIBC Static grounding protection for Type C FIBC located in potentially flammable/combustible gas or dust atmospheres

Universal Resistance Tester

The URT is designed to provide owners of Newson Gale **Earth-Rite®** and **Bond-Rite®** static grounding systems with a means of regularly testing the grounding settings for their system on a routine basis.

Periodic testing with the URT verifies that the grounding system's **GO/NO GO** settings are working in compliance with the recommendations of:

NFPA 77: "Recommended Practice on Static Electricity."

IEC 60079-32-1: "Explosive atmospheres. Part 32-1: Electrostatic hazards, guidance."

The easy to use tester consists of a pair of rotary switches that enable a competent electrical person to check the resistance level at which the grounding system should be working and conduct a PASS / FAIL test at the required setting.

Earth-Rite® and **Bond-Rite®** products that can be tested with the URT:

- > Earth-Rite® PLUS
- > Earth-Rite® FIBC (both 10 meg-ohm and 100 meg-ohm variants)
- > Bond-Rite® CLAMP
- > Bond-Rite® EZ
- > Bond-Rite® REMOTE
- > OhmGuard® (both 10 ohm and 100 ohm variants)



Universal Resistance Tester

Product Code: URT

Earth-Rite® FIBC Static grounding protection for Type C FIBC located in potentially flammable/combustible gas or dust atmospheres



Product Ordering Codes * Additional Options Available

Ordering Code	Product Description	IECEX / ATEX	North America
FIBC8P1EA1A1	ER FIBC 1 x 10 ⁹ monitoring system + X45F stainless steel clamp + 5 m (16 ft.) Hytrel Cable + junction box with Quick Connect.	•	
FIBC8P1UA1A1	ER FIBC 1 x 10 ⁹ monitoring system + X45F stainless steel clamp + 5 m (16 ft.) Hytrel Cable + junction box with Quick Connect.		•
FIBC7P1EA1A1	ER FIBC 1 x 10 ⁷ monitoring system + X45F stainless steel clamp + 5 m (16 ft.) Hytrel Cable + junction box with Quick Connect.	•	
FIBC7P1UA1A1	ER FIBC 1 x 10 ⁷ monitoring system + X45F stainless steel clamp + 5 m (16 ft.) Hytrel Cable + junction box with Quick Connect.		•
FIBC8MEA1A1	ER FIBC Exd 1 x 10 ⁹ monitoring system + X45F stainless steel clamp + 5 m (16 ft.) Hytrel Cable + junction box with Quick Connect.	•	
FIBC8MUA1A1	ER FIBC XP 1 x 10 ⁹ monitoring system + X45F stainless steel clamp + 5 m (16 ft.) Hytrel Cable + junction box with Quick Connect.		•
FIBC7MEA1A1	ER FIBC Exd 1 x 10 ⁷ monitoring system + X45F stainless steel clamp + 5 m (16 ft.) Hytrel Cable + junction box with Quick Connect.	•	
FIBC7MUA1A1	ER FIBC XP 1 x 10 ⁷ monitoring system + X45F stainless steel clamp + 5 m (16 ft.) Hytrel Cable + junction box with Quick Connect.		•

Contact Us > Your enquiry will be processed rapidly via our webform enquiry service. If you would prefer to call us, or e-mail us, please use the contact details provided below.

United Kingdom
 Newson Gale Ltd
 Omega House
 Private Road 8
 Colwick, Nottingham
 NG4 2JX, UK
 +44 (0)115 940 7500
 groundit@newson-gale.co.uk

Deutschland
 IEP Technologies GmbH
 Kaiserswerther Str. 85C
 40878 Ratingen
 Germany
 +49 (0)2102 5889 0
 erdung@newson-gale.de

United States
 IEP Technologies LLC
 417-1 South Street
 Marlborough, MA 01752
 USA
 +1 732 961 7610
 groundit@newson-gale.com

South East Asia
 ngsea@newson-gale.com